

Scuola Superiore Sant'Anna di Studi Universitari e di Perfezionamento



The Migration Toward the Optical Internet

Lesson 6

Luca Valcarenghi

(part of these notes are taken from

A. Fumagalli and J. Aracil, "Optical Internet: Available Technologies and Challenges", ICC 2002 Tutorial)



The Second Generation Optical Internet - Step I

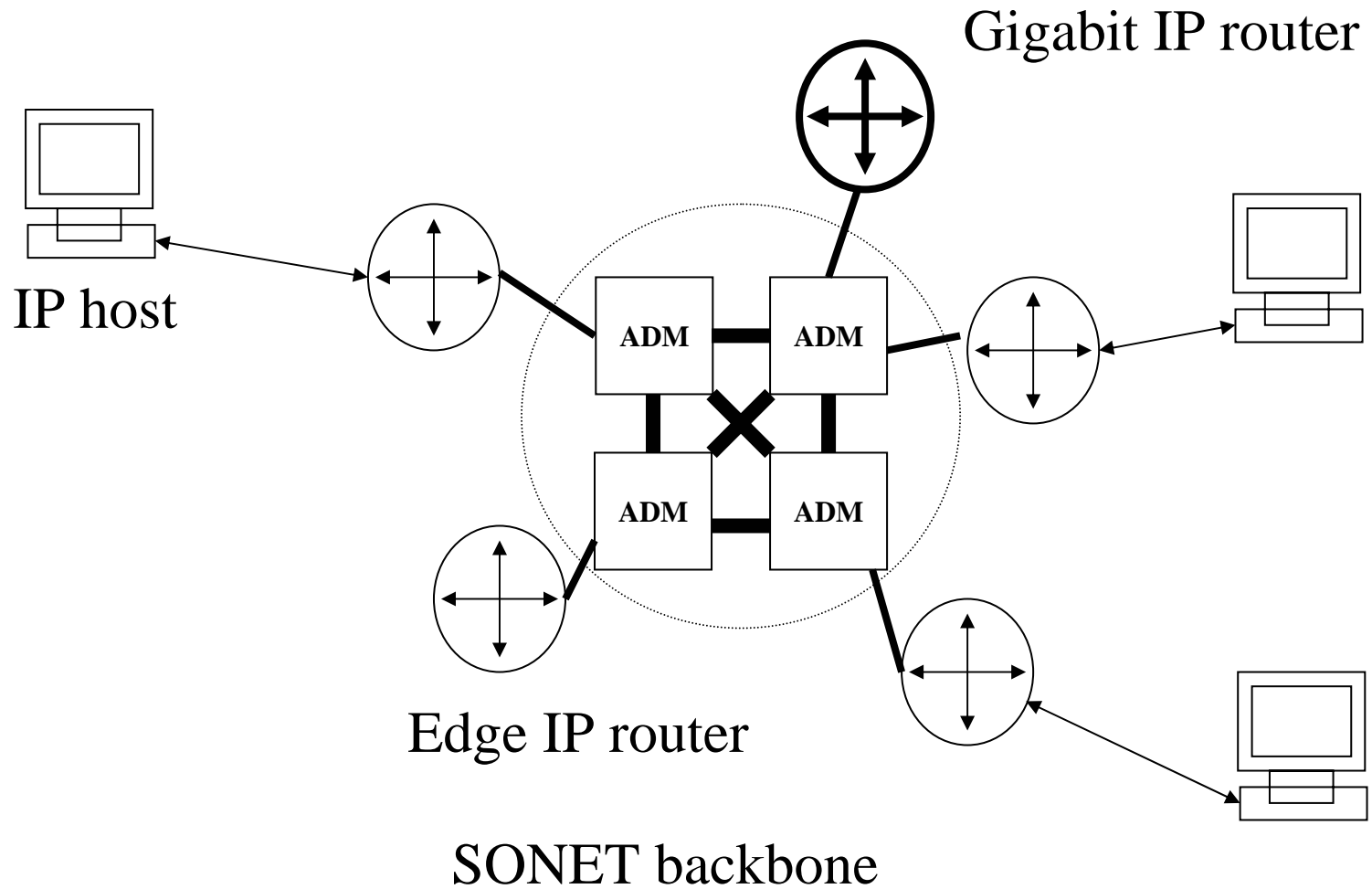



SGOI - Step I

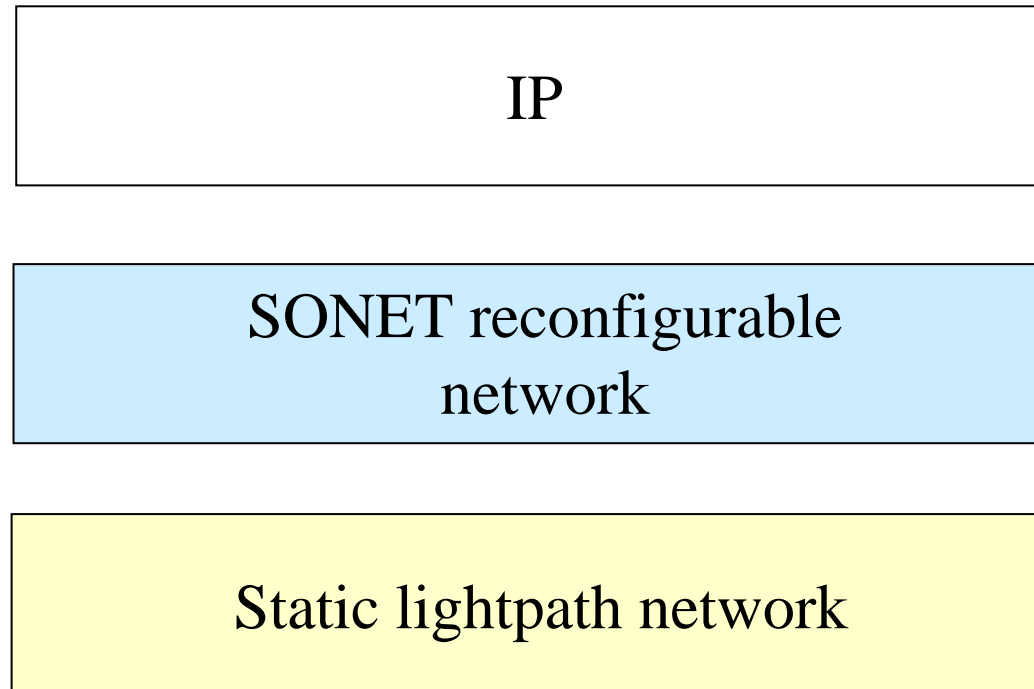



Protocol Architecture (Step I)

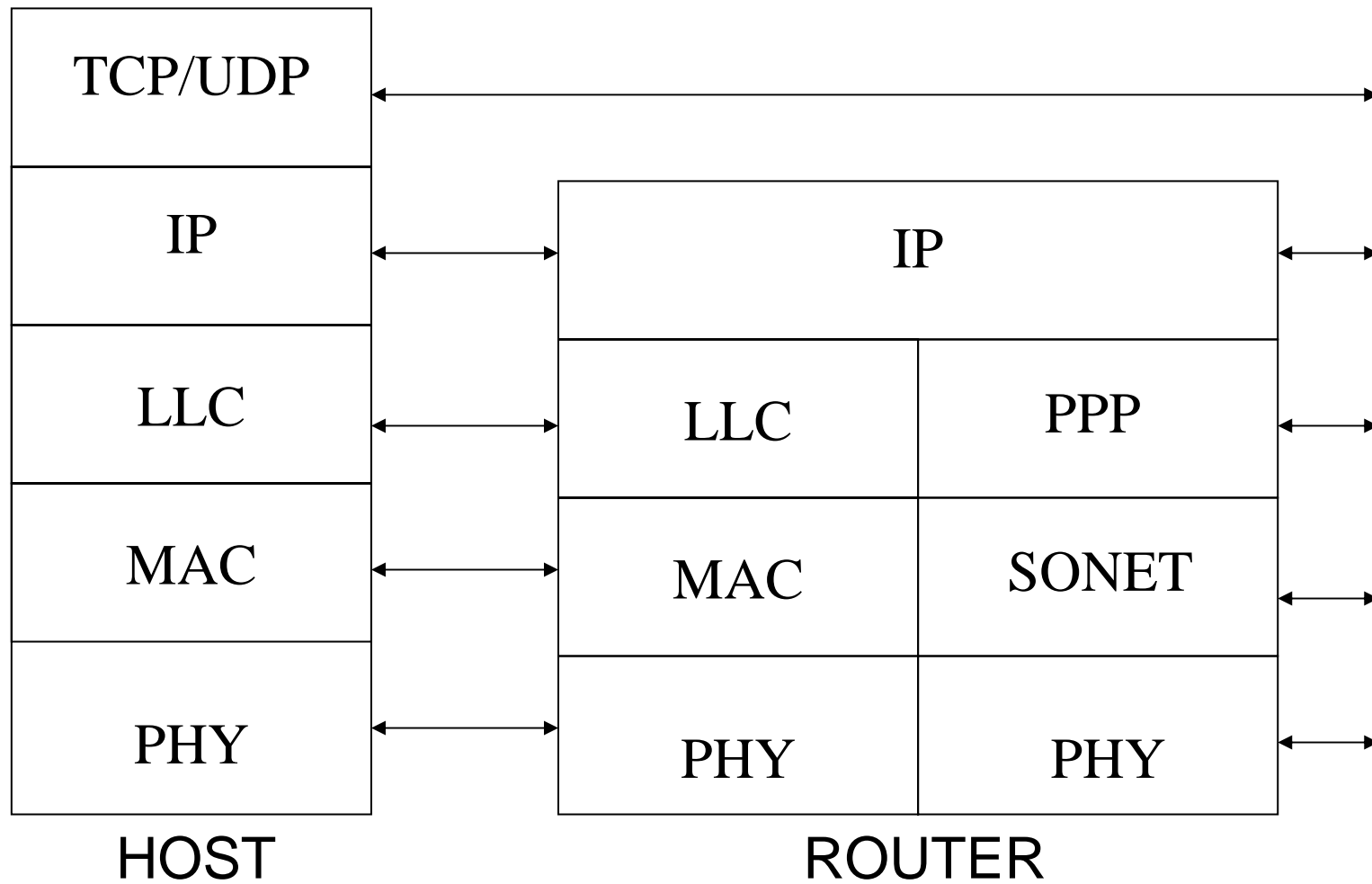



IP over (Reconfigurable) SONET - Advantages

- No “cell tax” (ATM overhead for IP packet size roughly 25%)
- Supports OAM operations
- Support of OC-48 (ATM SAR not feasible).
Internet demand is forcing move to OC-48



IP over (Reconfigurable) SONET - Disadvantages

- SONET can only provide bandwidth in tributary quantum
- SONET is intended for voice channels not datagrams
- SONET payload transparency compromised: need of additional scrambler



IP over (Reconfigurable) SONET versus IP over Optical Layer (WDM)

- IP over SONET adds physical layer overhead and synchronous operation not needed for asynchronous transport
- SONET allows for more granularity in bandwidth assignment
- In some cases (links between gigabit routers) a native IP over WDM is desirable but still the framing is an open issue



Generic Framing Procedure (GFP)

- Need of using SONET/SDH to carry signals for which SONET/SDH was not initially designed (i.e., data signals)
- Efforts by ANSI and ITU-T to provide a generic mechanism to adapt traffic from higher layer client signals over SDH/SONET or Optical Transport Networks (OTNs)
- GFP consists of both common and client-specific aspects
- Common aspects of GFP apply to all GFP-adapted traffic
 - Two modes of client signal adaptation are defined for GFP
 - PDU-oriented adaptation mode: frame-mapped GFP
 - block-code-oriented adaptation mode: transparent GFP
- Client-specific mapping definitions are underway for many protocols (e.g, Ethernet, HDLC)



GFP (2)

- In short, GFP defines a standard framing procedure for octet-aligned, variable length payloads for subsequent mapping into SONET/SDH SPE or OCh payload

Ethernet	IP/PPP	Other bearer services
GFP – client-specific aspects (payload-dependent)		
GFP – common aspects (payload independent)		
SONET/SDH path		OTN Och path



GFP for SONET/SDH

- Attempts to standardize the Virtual Concatenation (VC) of SONET/SDH paths
 - VC allows for relaxation of the “rigidity” of SONET/SDH bit rates
- Mapping of wide variety of data signals allowed
- Leveraging emerging capability of dynamically sizing virtually concatenated SONET/SDH paths using a link capacity adjustment scheme (LCAS)
 - LCAS provides a control mechanism to “hitless” increase or decrease the capacity of a link to meet the bandwidth needs of the application
- Combined VC, GFP, and LCAS offer an attractive option for carrying data networking protocols over transport networks, and present an alternative to the use of ATM and MPLS for transport oriented statistical multiplexing gain



Resilient Packet Ring (RPR)

- IEEE initiative for setting up a standard with code 802.17 for Resilient Packet Rings (RPRs)
 - Goal of 802.17 is to define and standardize a protocol suite optimized for high-speed ($> 1\text{Gb/s}$) packet transmission in resilient ring topologies
- The philosophy behind the RPR initiative consists of combining the resilient nature of ring topologies with the statistical multiplexing and QoS capabilities of a packet-optimized MAC protocol



The Next Generation Optical Internet - Step II?

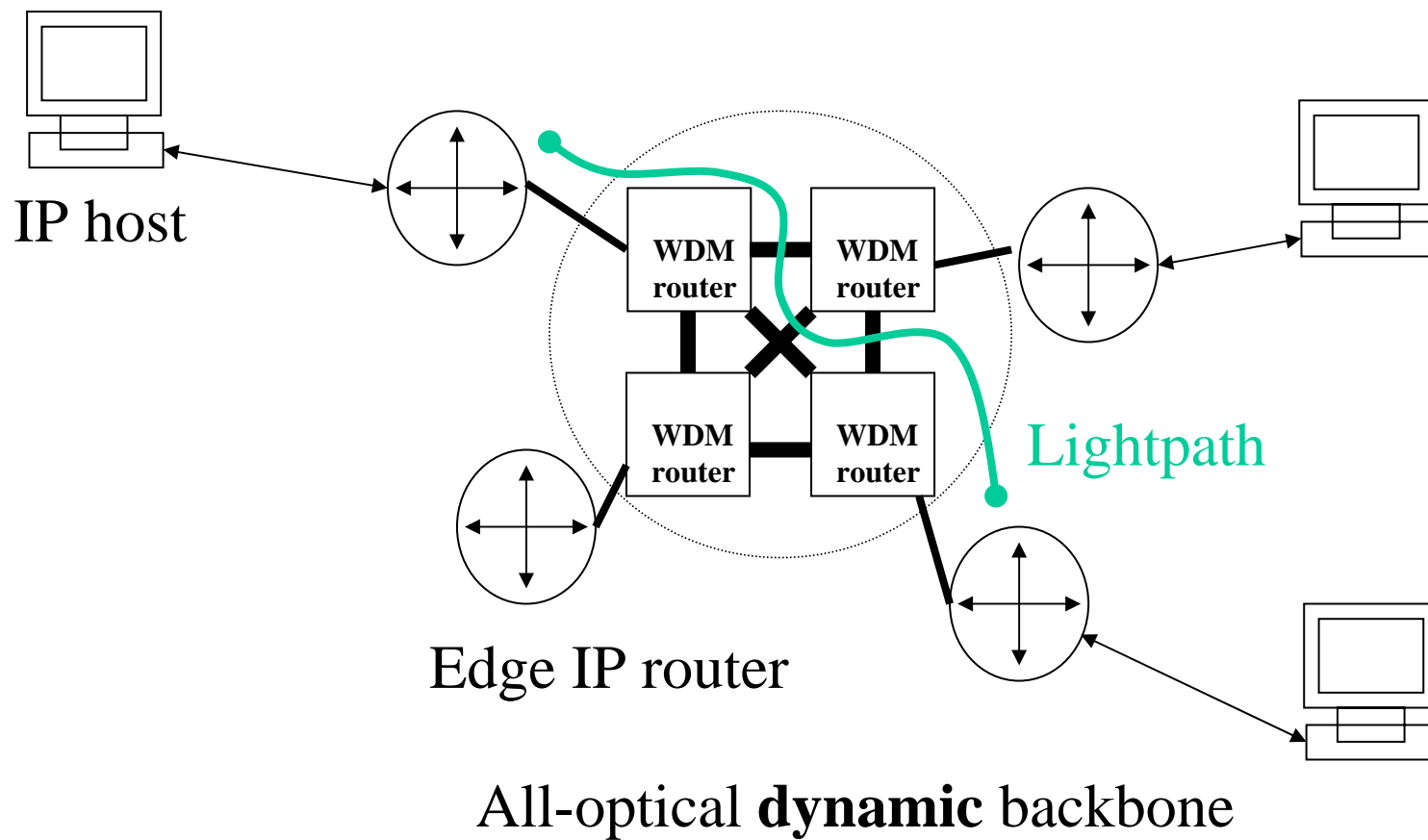



NGI - Step II

IP

Dynamic lightpath network



Optical Networking Trends

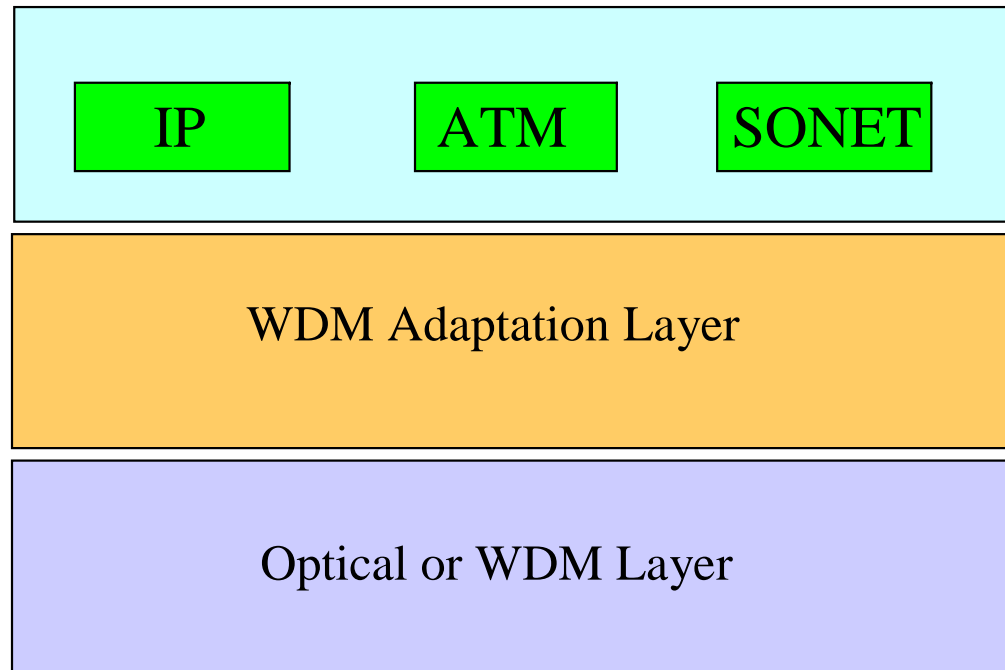



Protocol Architecture

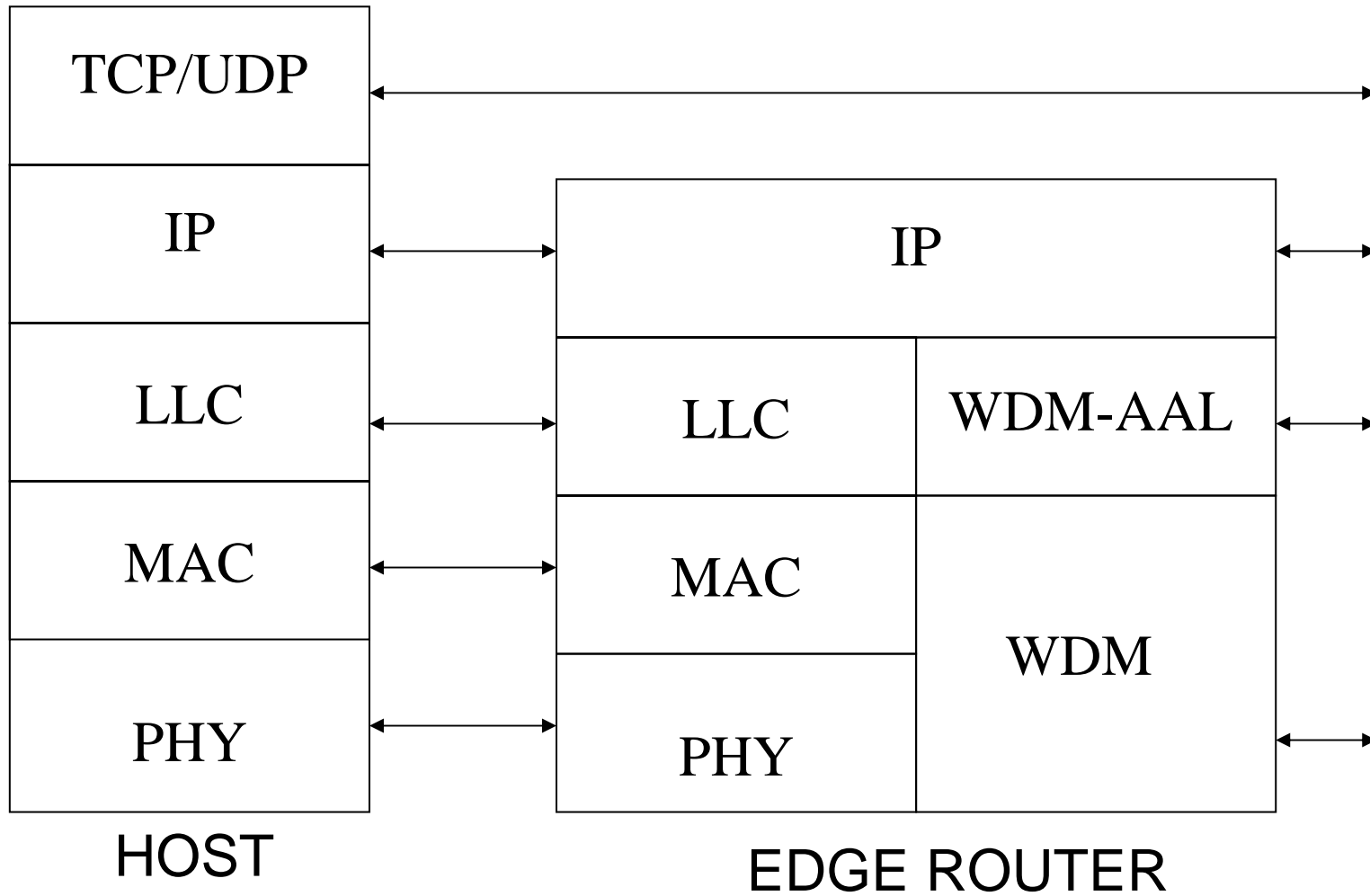



WDM AAL Features

- Frame delimitation and synchronization
- Multiprotocol encapsulation (LLC)
- Signaling for dynamic resources allocation (dynamic lightpath/optical burst)
- FEC



WDM AAL Example: Digital Wrappers (Lucent)

- Optical layer performance monitoring, FEC and ring protection *independent of input signal*





Digital Wrapper Features

- Substitutes SONET-like framing
- This scheme takes advantage of the need for opto-electronic regeneration to add additional capacity to the Optical Channel (OCh) client
- Permits to support all of the OCh-level Operation, Administration, and maintenance (OAM) requirements
- The use of digital wrapper technology provides functionality and reliability similar to SONET/SDH on a per wavelength basis (independently on the input signal)
 - Optical layer performance monitoring
 - FEC
 - ring protection and network restoration



WDM Routers

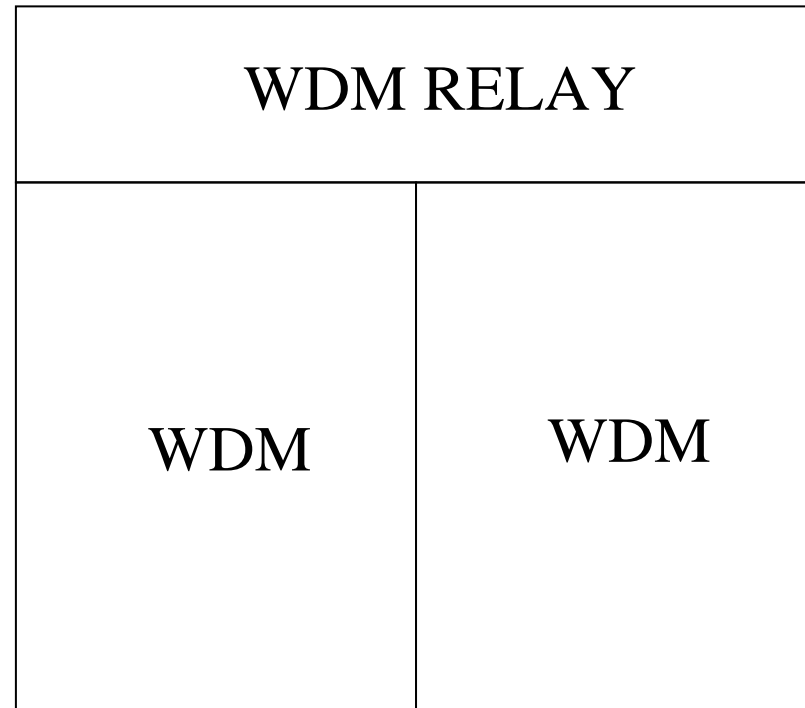

BACKBONE WDM ROUTER



The Optical Layer

- Optical fiber
- Optical Amplifiers (OA)
- Wavelength Routing Nodes (WRN)
- ITU Optical Layer



Optical Fiber

- Three transmission windows
 - first: 800-900 nm (Multimode)
 - second: 1240-1340 nm (Singlemode)
 - third: 1500-1650 nm (Singlemode)
- Potentially available bandwidth in each window ~ 20 THz
- Attenuation peak between second and third window dramatically reduced \Rightarrow second+third window
- Effective bandwidth limited by the device characteristics



Semiconductor Optical Amplifiers (SOA)

- **Broadband gain characteristics**
(work both at 1300 nm and 1550 nm)
- **Maximum bandwidth up to 100 nm**
- **Short switching time**
- **Gain fluctuation, polarization dependent, high coupling loss**
- **Suitable for single channel amplification**
- **Highly non-linear**



Doped Fiber Amplifiers

- Erbium-Doped Fiber Amplifiers (EDFA)
 - Short (S) λ band ~1450-1530 nm
 - Conventional (C) λ band ~1530-1570 nm
 - Long (L) λ band ~1570-1620 nm
 - Total available bandwidth ~ 170 nm (i.e., 200 channels with 0.8nm (“100GHz”) spacing)
 - ☺ High gain with no crosstalk, low noise figure, low loss
 - ☹ Gain function of λ , bigger dimensions, slow gain dynamic
- Other rare earth doped amplifiers x-DFA with peculiar characteristics (Praseodymium Doped Fluoride Amplifiers, Telluride Based ErbiumDoped Optical Amplifiers)



Linear Optical Amplifiers (LOA)

- Amplify multiple wavelengths
- Low gain transient
- Smaller size and lower power consumption than EDFA
- Suitable for metropolitan applications (switched environments)



Raman Amplifiers (RA)

- Distributed Amplifier
- Strong laser light (pump 100s mW)
- 20 nm amplification bandwidth per pump
- Multiple pumps are possible
- Any fiber can be used to couple pump and signal
- Advantages:
 - Low noise figure
 - Low power signal
 - Reduced non-linear effects of fiber



Wavelength Routing Nodes (WRN)

- OADM (Optical Add Drop Multiplexer)
- F-OXC (Fiber Optical Crossconnect)
- WR-OXC (Wavelength Routing Optical Crossconnect)
- WT-OXC (Wavelength Translating Optical Crossconnect)



WRN Schematic Representation

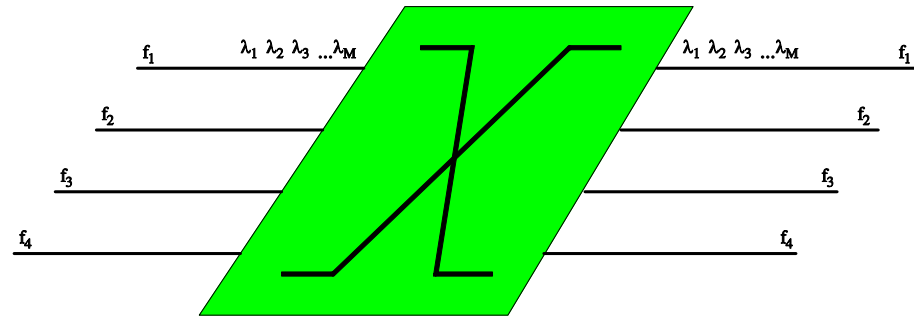

F-OXC

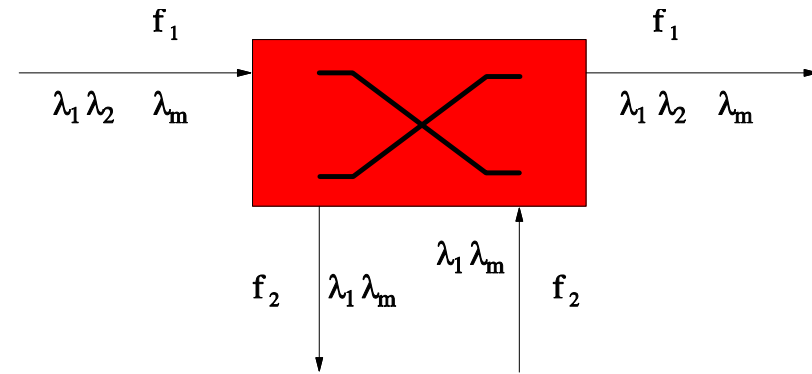

OADM

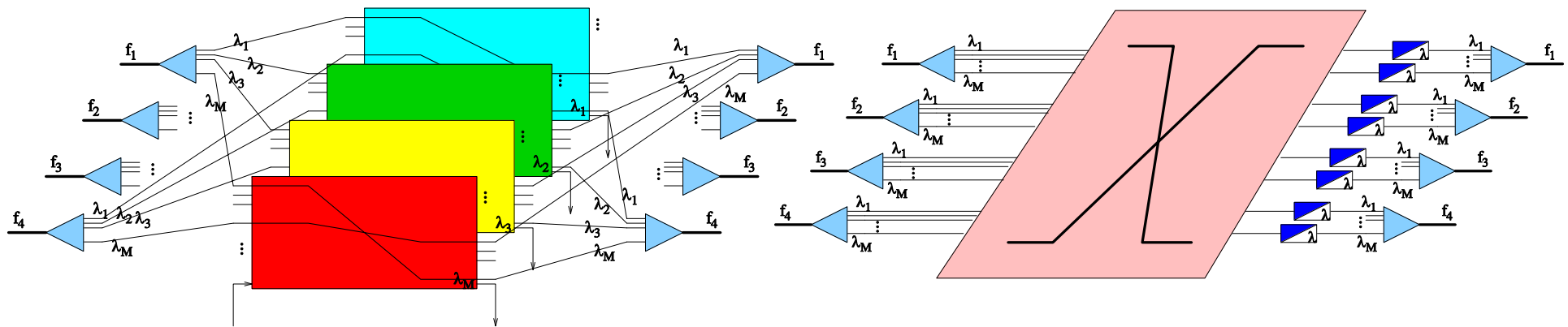

WR-OXC

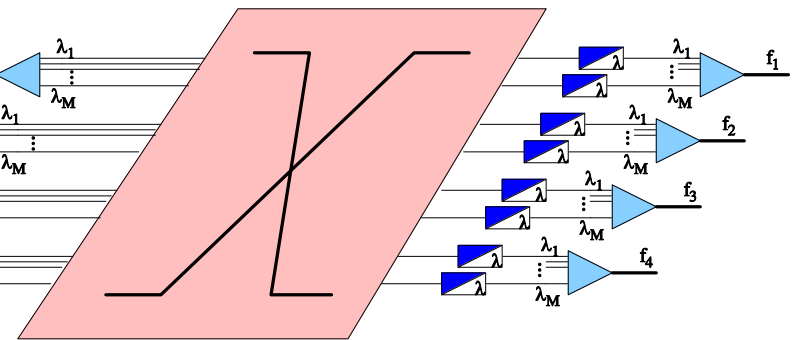

WT-OXC



WRN Functions

- **OADM** typically 2x2 **F-OXC** with λ adding and dropping
- **F-OXC** fiber switching with λ adding and dropping
- **WR-OXC** wavelength and fiber switching without λ conversion
- **WT-OXC** wavelength and fiber switching with λ conversion



ITU and Optical Layer

- International Telecommunications Union agency of United Nations devoted to standardize international communications
- Optical Layer defined by ITU inside the ISO-OSI Data Link layer (Rec. G.805, G.872)
- OL provides *lightpaths* to higher layers
- *Lightpath*: point-to-point all-optical connection between physically non-adjacent nodes



Optical Layer (OL)

Consists of:

- *Optical Channel (OCh)* sub-layer or *lightpath layer* \Rightarrow end-to-end route of the lightpaths
- *Optical Multiplex Section (OMS)* sub-layer \Rightarrow point-to-point link along the route of a lightpath
- *Optical Transmission Section (OTS)* sub-layer \Rightarrow link segment between two optical amplifier stages



Optical Sub-Layers

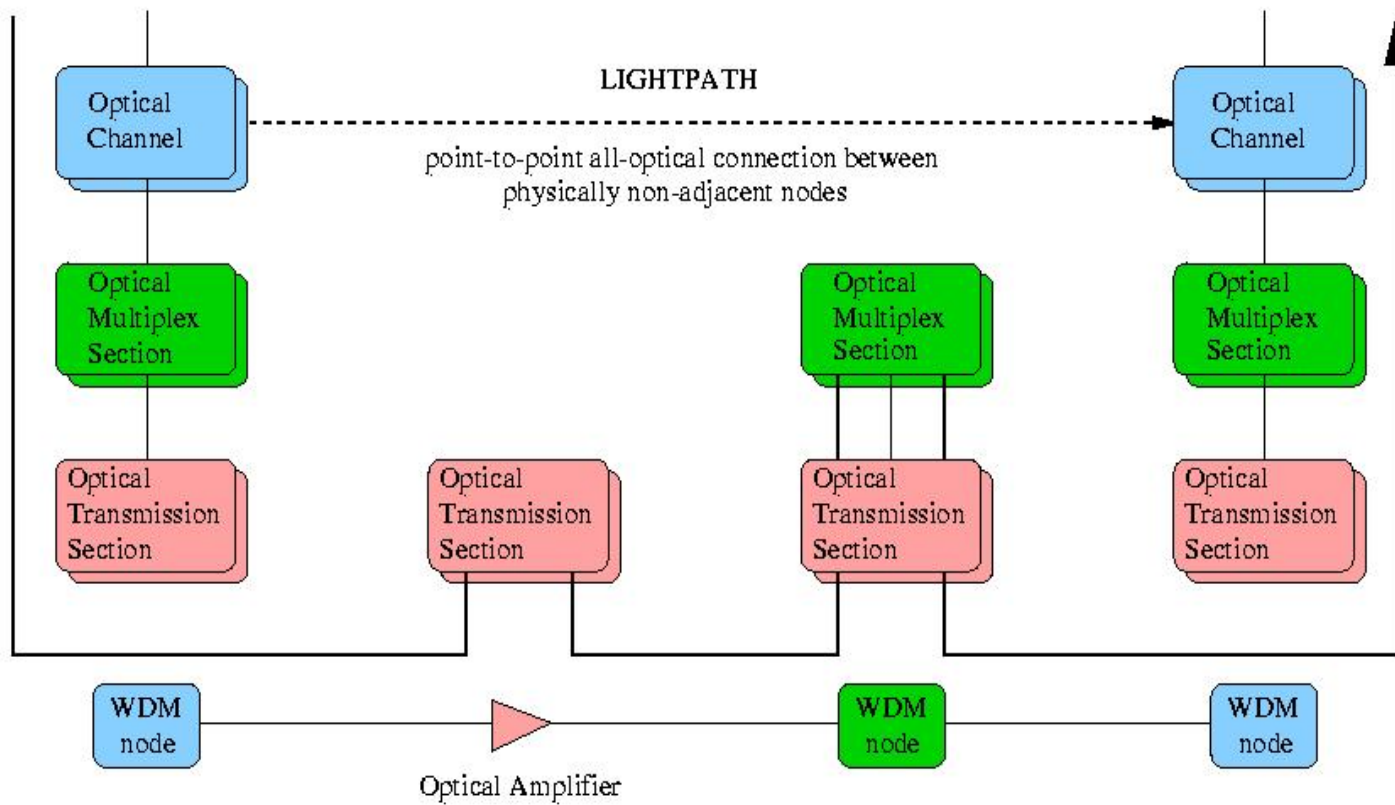



Inter-layer Design Issues

Issues in establishing, e.g., a lightpath :

- **OCh** layer \Rightarrow routing, protection, and management
- **OMS** layer \Rightarrow monitoring, multiplexing
- **OTS** layer \Rightarrow regeneration, amplification



Optical Network Techniques

- Static/Semi-static Lightpath
- Dynamic Lightpath
- Optical Packet and Burst Switching



Static/Semi-Static Lightpath

- Lightpath established when network is built
 - No active switches
 - No dynamic λ converters
 - Fixed routing pattern at the nodes
 - Logical topology on top of physical topology
- Periodic network reconfigurations
 - Active devices controlled manually or via signaling
 - Logical topology may be changed to best suit traffic characteristics



Static/Semi-Static Lighthpath Networks

- Design issues and the RWA problem
- Survey of network architectures
- Effect of transmission constraints
- Multicast in WDM networks
- OL protection and restoration mechanisms
- Testbeds



Optical Layer Dimensioning

- Each fiber can carry up to 128 λ 's each operating at 10 Gb/s [Chabt *et al.* '98]
- A lightpath demand matrix is given
- Demands are obtained by traffic models (e.g., traffic models for IP layer)



Static RWA Problem

- The **R**outing and **W**avelength **A**ssignment (**RWA**) problem:

given a physical topology and a set of end-to-end lightpath demands determine a route and a λ assignment for each request

- RWA (with no λ conversion) is a NP-complete problem [Chlamtac '92]
- Approximate and heuristic solutions available



Dynamic Lightpath Networks

- Dynamic routing and channel assignment
- Network scenario and layering
- Intra-ring dynamic lightpath set up



Static Lightpath

- IP directly over WDM to reduce
 - complexity
 - end-to-end delay
 - transmission overhead

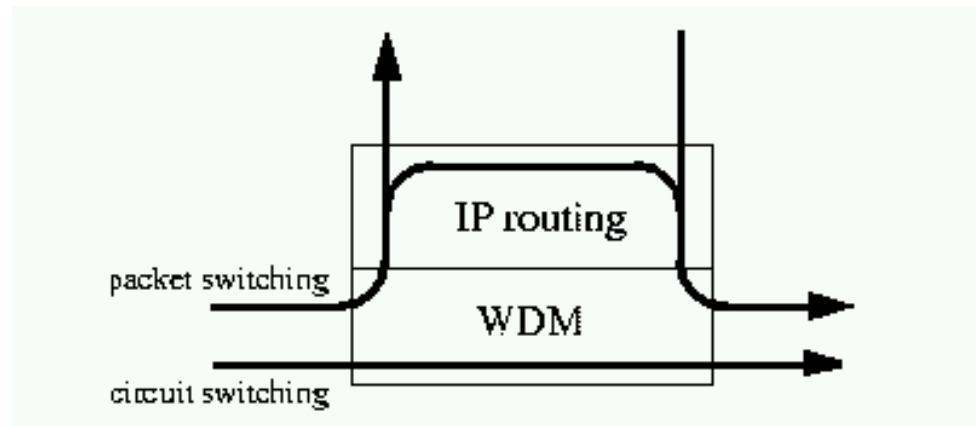



Dynamic Lightpath

- *Reconfigurable* networks
- **WT-OXC, WR-OXC**, and active components used
- More expensive than fixed networks
- Adaptive to varying traffic demands
- Restoration as opposed to protection



Dynamic Routing and Wavelength Assignment

- Logical connection (lightpaths) requests arrive randomly
- Network state:
 - all active connections with their optical path (route and wavelength assignment)
- Real-time algorithms needed to accommodate requests
- Delay set-up, blocking and fairness issues



Intra-Ring Dynamic RWA

- Problem: on-line **R**outing and **W**avelength **A**ssignment (**RWA**) of lightpaths
- Solutions:
 - Centralized control [ONRAMP]
 - Distributed control [LightRing]



Centralized Control

- Source node sends lightpath request to controller
- Controller checks on available resources and grants or rejects access
- If access is granted, controller must select wavelength for lightpath
- Controller keeps track of available resources



Wavelength Selection at Controller

- Random algorithm (RD)
- First-Fit algorithm (FF)
- Max-Sum algorithm (MS)
- Greedy algorithm with Wavelength Converter (WC)



Distributed LightRing (LR) Multi-token Control

- Controller is not required
- Nodes are updated on network status by means of a multi-token control
- One token per data channel
- Token transmitted on control channel
- Token control for on-demand lightpath establishment



Optical Packet Switching

- Experimental phase
- Switch optically routes packets based on their header
- Enabling technologies
- Routing node structure
- Proposed solutions



Enabling Optical Technologies

- Multiplexing (bit and packet interleaving)
- Demultiplexing
- Synchronization
- Packet header detection
- Buffering
- Logical gates
- High speed switches

Routing Node Structure

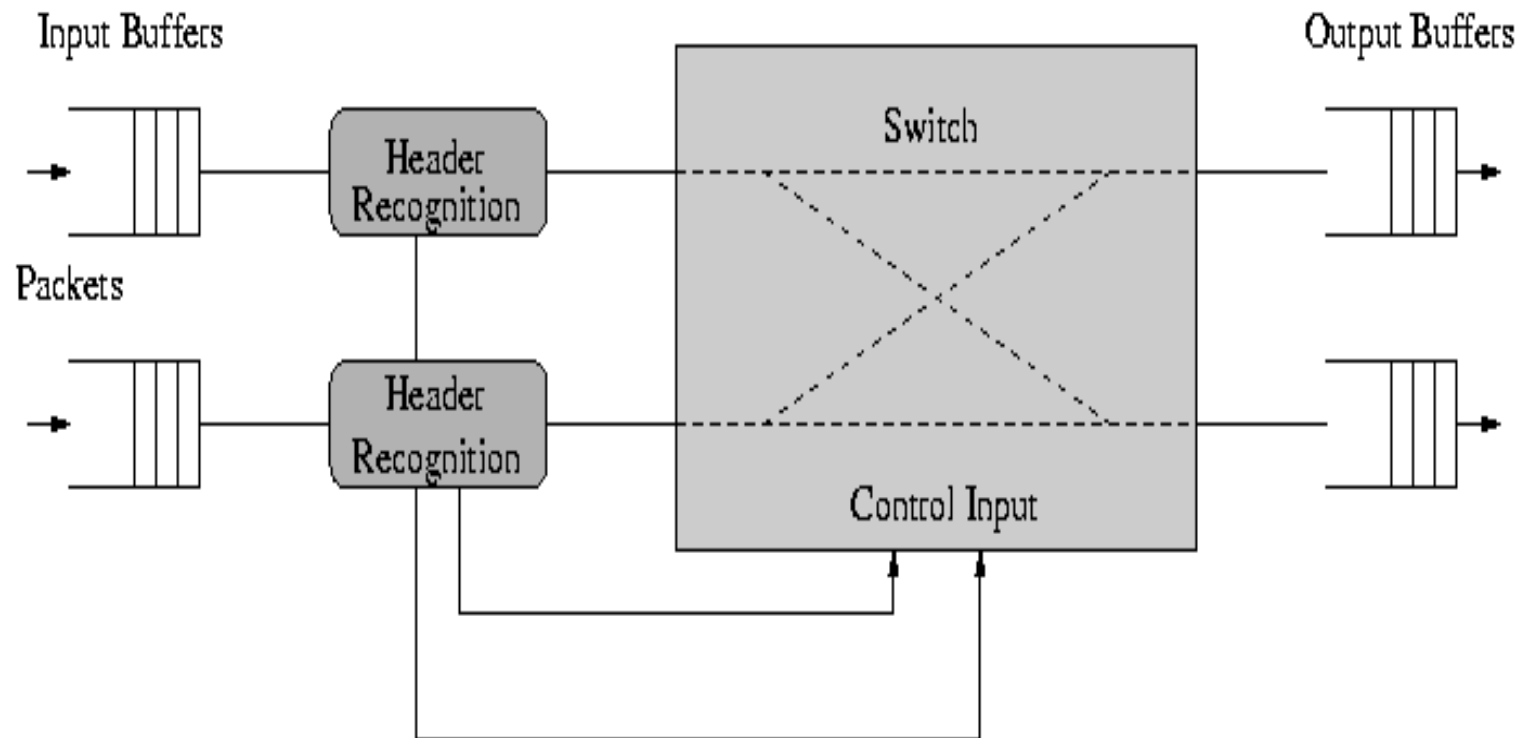



Routing Node Functions

- Synchronization
 - utilization of variable delay lines
- Header Recognition
 - performed either optically or electronically while the remainder of the packet is optically buffered
- Buffering
 - *feed-forward* and *feed-back* delay lines structures
- Routing
 - *deflection* or *hot-potato* either with or without small input and output buffer



Optical Burst Switching (OBS)

- Packets are aggregated to form a single burst of data
- Burst is transmitted optically, in a bufferless network
- Reservation for network resources is performed by sending a control message that propagates ahead of the burst
- Reservation lasts only the burst duration



OBS vs. Optical Packet Switching

- OBS advantages
 - OBS more commercially viable technique because of switching speed and buffering
 - OBS can be designed to not require optical buffering
- OBS drawbacks
 - Burst switching schemes and burst size need to be studied



OBS vs. Optical Circuit Switching (Static/Semi-Static Lightpath)

- OBS advantages
 - More bandwidth flexible
 - Burst statistical multiplexing
- OBS drawbacks
 - Reservation policies required
 - Reservation contention



OBS Reservation Policies

- Centralized
 - Central controller handle all requests and grant access to network resources
- Distributed
 - The nodes coordinate themselves to handle resource contention



OBS Distributed Reservation Policies

- Tell-and-wait (TAW)
 - Request packet sent to destination and burst held at the source
 - If all switches along source-destination path can accommodate burst
⇒ burst transmitted
- Tell-and-go (TAG)
 - Request packet sent to destination
 - Burst sent immediately after request packet without waiting for confirmation
- Just-enough-time (JET)
 - Delay between request packet and the burst transmission
 - Delay set to be larger than request packet processing time at the nodes ⇒ no need for buffering at the intermediate nodes